

EIB 36-Plating Adapter User Manual



Document Revision 2.0
Last Revised: October 29, 2008

© Neuralynx, Inc.
105 Commercial Drive, Bozeman, MT 59715
Phone 406.585.4542 • Fax 406.585.9034

www.Neuralynx.com
support@Neuralynx.com

Table of Contents

1	EIB 36-Plating Adapter Overview	3
2	Circuit Board Layout	3
3	Connecting the EIB-36 Plating Adapter to an EIB	4
4	Measuring Impedance	5

List of Figures and Tables

Figure 2-1	Circuit Board Top View	3
Figure 2-2	Circuit Board Bottom View	3
Figure 3-1	Mounting Screws (4)	4
Figure 3-2	Set Screw	4
Figure 3-3	Connection to EIB-36 9_Drive	5
Figure 4-1	Plating Adapter Ground Locations	6

1 EIB 36-Plating Adapter Overview

The EIB-36 Plating Adapter is a simple interface for allowing impedance measurements while plating. The adapter connects to an EIB-36 device on one end and a stereotaxic device on the other. The open design allows direct access to each channel for impedance measurements.

2 Circuit Board Layout

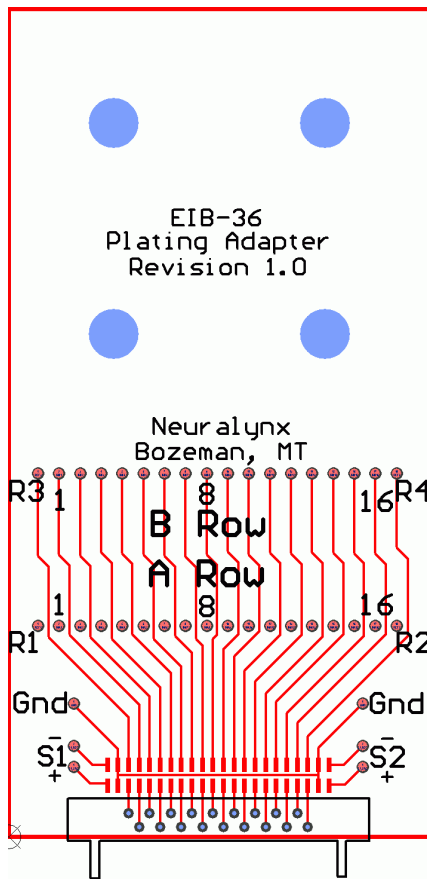

Figure 2-1 Circuit Board Top View

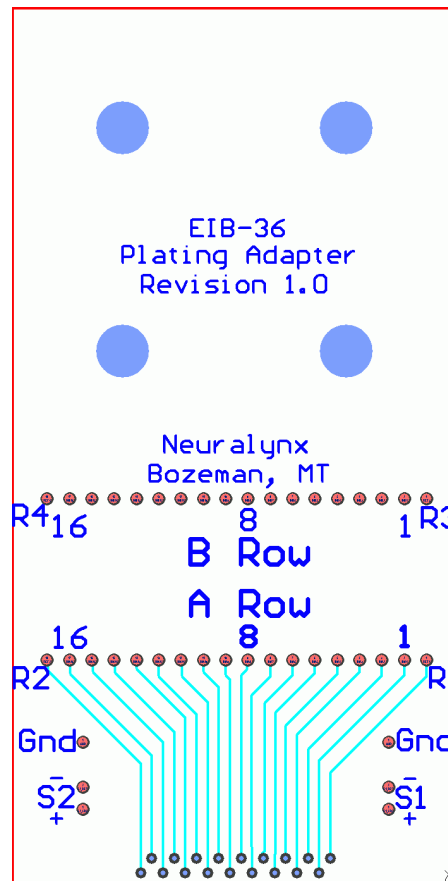

Figure 2-2 Circuit Board Bottom View

3 Connecting the EIB-36 Plating Adapter to an EIB

The plating adapter is designed to be used with a stereotaxic holding rod. The Plating Adapter has four large holes arranged in a 0.5 in x 0.5 in square for securing a mounting block (figure 3-1) that holds a 0.312 inch diameter stereotaxic rod (not included).

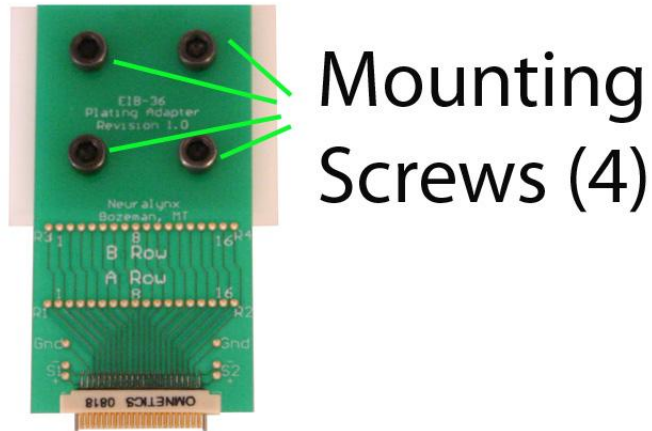

Figure 3-1 Mounting Screws (4)

Secure the rod to the adapter by tightening the set screw (figure 3-2)

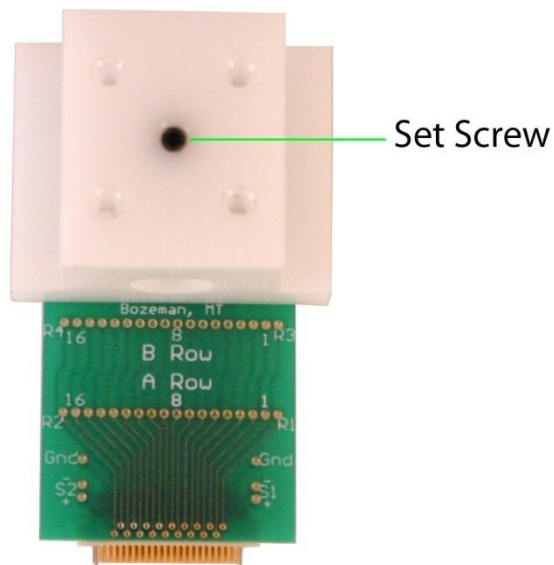

Figure 3-2 Set Screw

Place the adapter on top of the mounting block and secure it with the four provided screws. Once the plating adapter is secured to the stereotaxic rod, the plating adapter can be connected to an EIB-36 (Figure 3-3). The Plating Adapter has a male Omnetics connector that will connect to any variation of EIB within the EIB-36 family.

*** Note *** Although the Omnetics connectors are soldered and epoxied to the printed circuit board (PCB) for strain relief, be careful not to exert too much pressure on this connection.

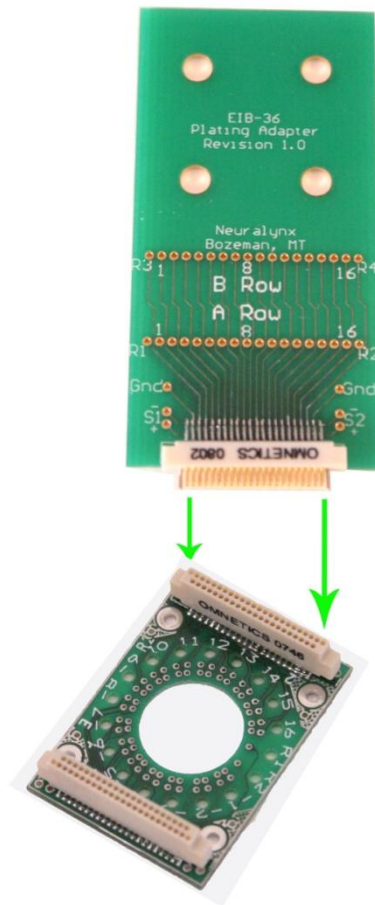

Figure 3-3 Connection to EIB-36 9_Drive

All of our Omnetics connectors have guide pins to help you align male and female connectors properly. Also, the black lettering on each connector should be on the same side.

4 Measuring Impedance

There are two ground connections on the Plating Adapter, each of which can be used for a ground point for your impedance measuring device (Figure 4-1). This ground should

be tied to the ground that is inserted into the saline/gold bath. Connect the other “line” end of the impedance probe to the test point of the channel you wish to measure.

The reference channel test points are labeled R1-R4 and sit on the outer edges of the PCB. Channels A1 through A16 are on the row of test points closer to the Omnetics connector. Channels B1 through B16 are on the row of test points closer to the center of the PCB. Note that the same test points are available on each side of the PCB.

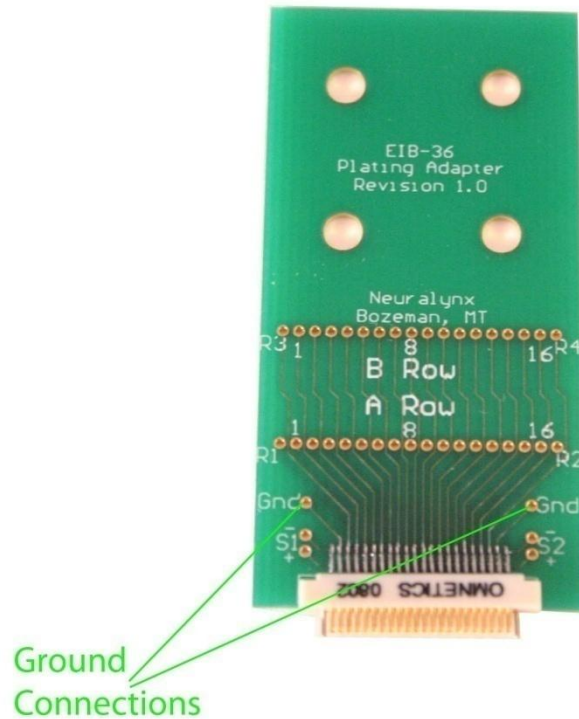

Figure 4-1 Plating Adapter Ground Locations